ONE ICC REACTOR VISION

by

M. J. Schaffer

General Atomics

**Presented at Fusion Summer Study
Snowmass, CO, 2002 July 8–19**

D-³He Fusion Energy Might be a Desirable End Product.

A few years ago, I realized it might be attainable in a Steady State FRC.

D-³He reactivity is low. — Requires large plasma pressure.

- FRC has *engineering* $\langle \beta^2 \rangle^{1/2} \approx 1$ at coils. ✓
- D-³He ignition temperature is high. — Requires low B.
 - FRC has low B in the hot central core, so synchrotron radiation can be acceptably low. ✓
- D-³He reactivity is low. — Requires excellent confinement.
 - Must achieve stable confinement *about as good as advanced tokamak*
 - a challenge for any MFE concept!
 - FRCs are unstable theoretically but stable experimentally!!
 - Have to figure this out!!!
 - Basic science and Fusion goal (in my personal priorities).

Vision: Oblate, Steady State, D-³He Fusion FRC Reactor Cartoon

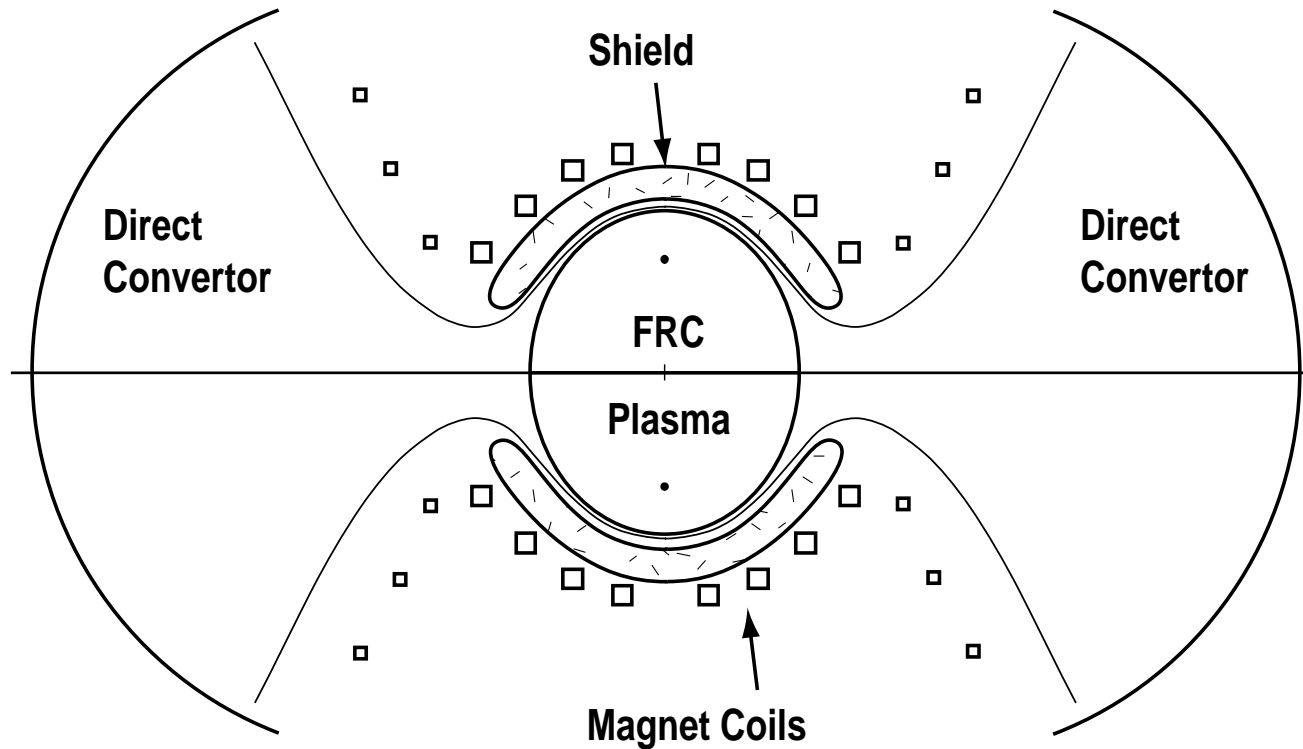

- Unobstructed plasma exhaust
- Direct conversion of charged particle energy
- Superconducting coils

Need to Study FRC Stability. SSX-FRC Experiment will Do This.

- Make FRCs by merging counterhelicity spheromaks.
 - “Conventional” FRCs
 - “Doublet” FRCs with controlled $\pm B_T$ regions (New)
- Study equilibrium and stability.
 - Test Omelchenko’s predictions.
 - SSX features 600 internal magnetic probes (200 x 3 axis).
- Could study wall-stabilized oblate FRCs with additional modifications .

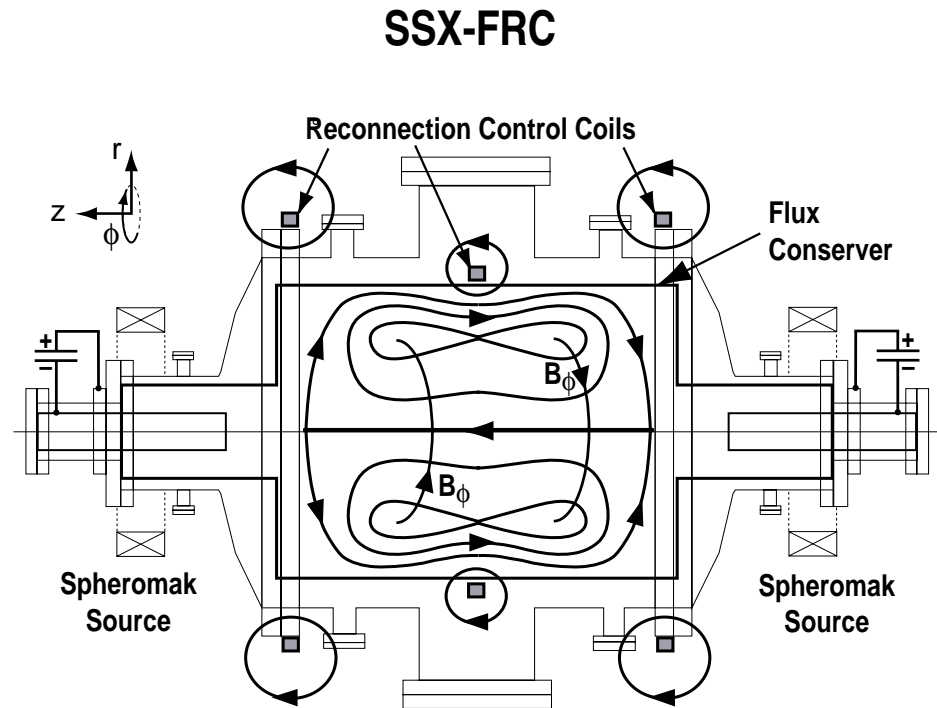

It is *Essential* to make High-Flux FRCs for Future Experiments. Proposing a Scalable FRC Formation Method:

HI-FLUX: Merge Inductively Driven Double Helix Plasmas into an FRC

- Inductively driven RFPs make *high-flux* magnetized plasma.
- *Double Helix* plasmas propagate poloidal- and toroidal-like flux from sources to chamber/
- Opposite-helicity double helices reconnect and relax to an FRC.
 - Strongly 3-dimensional reconnection
 - Might not work!
 - At frontiers of plasma physics (fusion, astro and basic), all because I do fusion (ICC and tokamak).

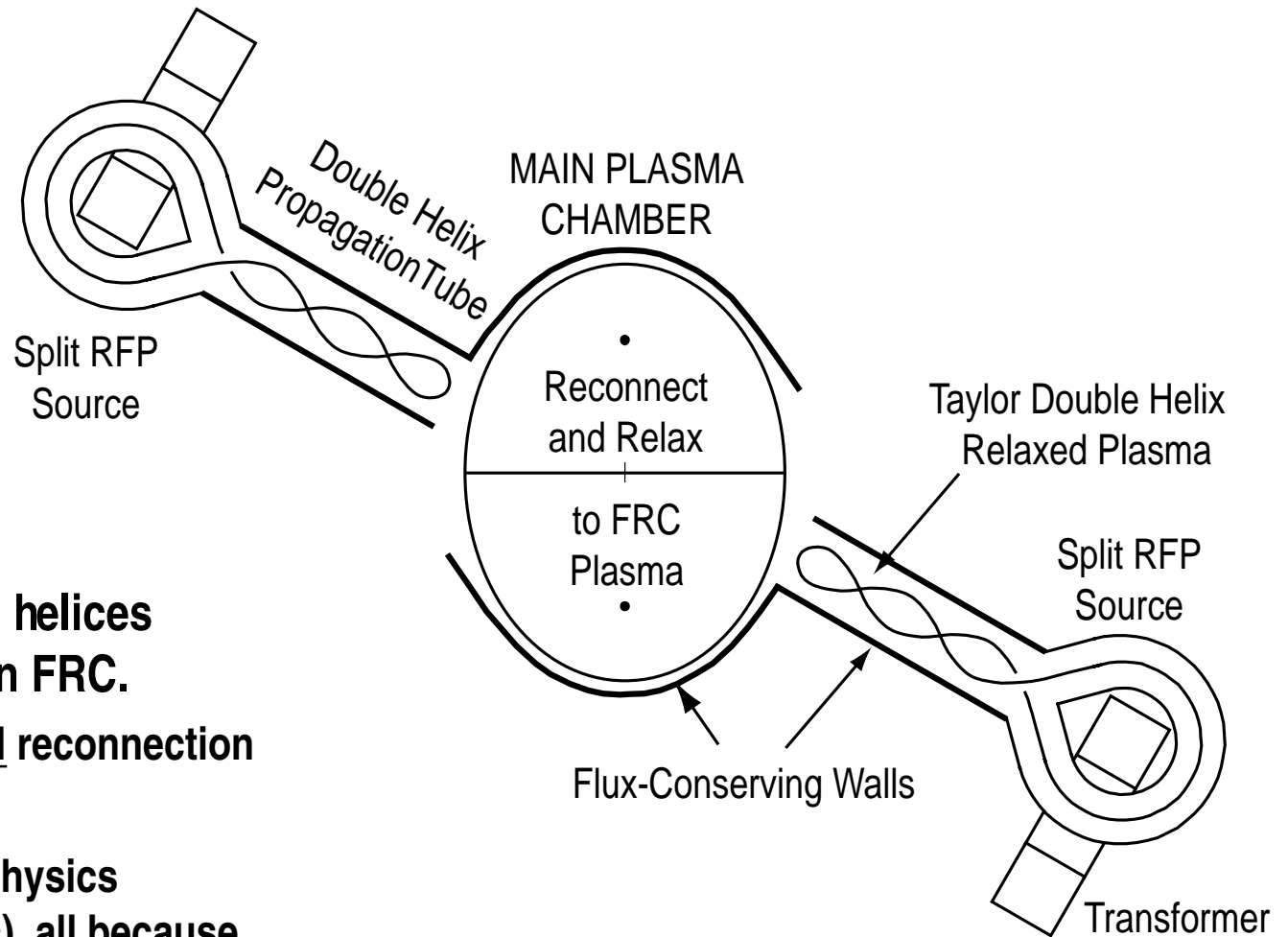

In Conclusion...

I've worked about half of my career in Mainline fusion, half in ICCs.

I have always found interesting problems to work on.

I always learn new stuff.

I get better ideas each time around.

ICCs, Base Program and Mainline Tokamak research all give me ideas.

The probability of success of any particular new idea in this field is fairly low.

Some of our ideas work well, some don't.

**We need to know when to drop an idea and try something new,
both as persons and as a fusion program.**